

# Panasonic®

## Operating Instructions <Quick Start Guide>

4K Video Camera

## Manuel d'utilisation <Guide de prise en main rapide>

Camera vidéo 4K

Model No. / Modèle N°

**HC-X2100/  
HC-X1600/  
HC-X1200**

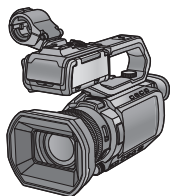

Please read these instructions carefully before using this product, and save this manual for future use.

Veillez lire attentivement les présentes instructions avant d'utiliser ce produit, et conserver ce manuel pour utilisation ultérieure.

More detailed operating instructions are available in "Operating Instructions <Complete Guide>" (HTML format/PDF format). This can be viewed with a PC or smartphone.

Un manuel d'utilisation plus détaillé est disponible en "Manuel d'utilisation <Guide complet>" (Format HTML/format PDF). Il peut être visionné à l'aide d'un PC ou d'un smartphone.

<https://panasonic.jp/support/video/oi/X2100/index.html>



Web Site: <http://www.panasonic.com>

E

DVQX2729ZA  
F1224MZ0

# Information for Your Safety

---

---

## **WARNING:**

To reduce the risk of fire, electric shock or product damage,

- Do not expose this unit to rain, moisture, dripping or splashing.
- Do not place objects filled with liquids, such as vases, on this unit.
- Use the recommended accessories.
- Do not remove covers.
- Do not repair this unit by yourself. Refer servicing to qualified service personnel.

This unit is intended for use in moderate climates.

Product identification marking is located on the bottom of the unit.

## ■ **Concerning the battery**

### **Warning**

Risk of fire, explosion and burns. Do not disassemble, heat above 60 °C or incinerate.

### **CAUTION**

- Danger of explosion if battery is incorrectly replaced. Replace only with the type recommended by the manufacturer.
- When disposing of the batteries, please contact your local authorities or dealer and ask for the correct method of disposal.

## ■ **EMC Electric and magnetic compatibility**

This symbol (CE) is located on the rating plate.

## ■ Disposal of Old Equipment and Batteries

### Only for European Union and countries with recycling systems



These symbols on the products, packaging, and/or accompanying documents mean that used electrical and electronic products and batteries must not be mixed with general household waste.

For proper treatment, recovery and recycling of old products and used batteries, please take them to applicable collection points in accordance with your national legislation.

By disposing of them correctly, you will help to save valuable resources and prevent any potential negative effects on human health and the environment.

For more information about collection and recycling, please contact your local authority.

Penalties may be applicable for incorrect disposal of this waste, in accordance with national legislation.



#### **Note for the battery symbol (bottom symbol):**

This symbol might be used in combination with a chemical symbol. In this case it complies with the requirement set by the Directive for the chemical involved.

**(For the X1600)****Declaration of Conformity (DoC) for EU:**

Hereby, “Panasonic Entertainment & Communication Co., Ltd.” declares that this product is in compliance with the essential requirements and other relevant provisions of Directive 2014/53/EU.

Customers can download a copy of the original DoC for our RE products from our DoC server:

<https://www.ptc.panasonic.eu/compliance-documents>

Importer for EU: Panasonic Marketing Europe GmbH

Hagenauer Strasse 43, 65203 Wiesbaden, Germany

Authorized Representative in EU: Panasonic Marketing Europe GmbH

Panasonic Testing Centre, Winsbergring 15, 22525 Hamburg, Germany

5.15 - 5.35 GHz band is restricted to indoor operations only in the following countries.

AT	BE	BG	CZ	DK	EE	FR	DE	IS	IE	IT	EL	ES	CY	LV	LI	LT	LU
HU	MT	NL	NO	PL	PT	RO	SI	SK	TR	FI	SE	CH	HR	UK(NI)	RS		

**Declaration of Conformity (DoC) for UK:**

Hereby, “Panasonic Entertainment & Communication Co., Ltd.” declares that this product is in compliance with the essential requirements and other relevant provisions of the Radio Equipment Regulations 2017.

Customers can download a copy of the original DoC for our RE products from our DoC server:

<https://www.ptc.panasonic.eu/compliance-documents>

Importer for UK: Panasonic UK, a branch of Panasonic Marketing Europe GmbH

Maxis 2, Western Road, Bracknell, Berkshire, RG12 1RT

5.15 - 5.35 GHz band is restricted to indoor operations only in the UK.

**Maximum power and operating frequency bands of transmitter**

Type of wireless	Frequency band (central frequency)	Maximum power (dBm e.i.r.p.)
WLAN	2412-2462 MHz	13 dBm
	5180-5320 MHz	13 dBm
	5500-5700 MHz	13 dBm
	5745-5825 MHz	13 dBm

**For Turkey**

AEEE Yönetmeliğine Uygundur.  
AEEE Complies with Directive of Turkey.

Note regarding the Power Management function specified under COMMISSION REGULATION (EC) No 1275/2008 implementing Directive 2009/125/EC of the European Parliament and of the Council.

This device is designed and manufactured for use at a broadcasting station and/or in a similar environment.

This device is not equipped with a Power Management function or the Power Management function is set to OFF as it will prevent the device from fulfilling its intended purpose for the reasons below.

1. If the device is a Studio Camera, a Weather Camera, a Mixer or other processor:  
A Power Management function may cause the device to suddenly stop during recording or while On Air.
2. If the device is a Studio Monitor:  
A Power Management function may cause video for the confirmation of whether a signal is normal, or whether the signal has been lost, to be un-viewable.
3. If the device is a Camera Recorder:  
A professional camera recorder must be able to start quickly at any time, but a Power Management function will cause an increase in the time taken to resume from Stand-by mode.

# Cautions for use

---

**Keep this unit as far away as possible from electromagnetic equipment (such as microwave ovens, TVs, video games etc.).**

- If you use this unit on top of or near a TV, the pictures and/or sound on this unit may be disrupted by electromagnetic wave radiation.
- Do not use this unit near cell phones because doing so may result in noise adversely affecting the pictures and/or sound.
- Recorded data may be damaged, or pictures may be distorted, by strong magnetic fields created by speakers or large motors.
- Electromagnetic wave radiation generated by microprocessors may adversely affect this unit, disturbing the pictures and/or sound.
- If this unit is adversely affected by electromagnetic equipment and stops functioning properly, turn this unit off and remove the battery or disconnect AC adaptor. Then reinsert the battery or reconnect AC adaptor and turn this unit on.

**Do not use this unit near radio transmitters or high-voltage lines.**

- If you record near radio transmitters or high-voltage lines, the recorded pictures and/or sound may be adversely affected.

**When this unit is turned on, do not use it in direct contact with the skin for a long period of time.**

- When using this unit for a long period of time, use a support such as a tripod. Low temperature burns may result if any high temperature part of this unit or hot air from the ventilation openings on the front side of the hand strap of this unit is in direct contact with the skin for a long period of time.

## Caution regarding the lens and the viewfinder

- Do not aim the lens or the viewfinder\* at the sun or strong light. Doing so may cause the unit to malfunction.
- \* **X2100** / **X1600** is equipped with a viewfinder. **X1200** is not equipped with a viewfinder.

## Before using the unit

The date and time have not been set at the time of purchase. Before use, make sure you set the clock and time zone so that date and time information is correctly recorded. (→ 24)

- When using this product during rain or snow or when at the beach, be careful that water, sand and/or dust do not get inside the camera.

- Clips recorded with devices other than this unit are not supported by this unit.
  - Hold the handle or grip when carrying the camera, and handle it carefully.
  - If you prepare to record important images, always shoot some advance test footage to verify that both pictures and sound are being recorded normally.
  - [BATTERY]/[AC]/[NETWORK]\* in [ECO MODE] is set to [ON] at the time of purchase. When there is no button operation or LCD monitor touch operation performed for a certain time, the power turns off automatically.  
The power consumption of this unit may increase if [BATTERY]/[AC]/[NETWORK]\* in [ECO MODE] is set to [OFF].
  - For more information about the energy efficiency of the product, please visit our website, [www.panasonic.com](http://www.panasonic.com), and enter the model number in the search box.
- \* When using **X1200**, [NETWORK] is not displayed.

## Battery

- Always remove the battery from the unit after use.

## Charging lamp during charging

When the charging lamp is flashing, the following should be considered.

### Flashing with approx. 4 second period (on for approx. 2 seconds, off for approx. 2 seconds):

- When the battery is over discharged or the temperature of the battery is too high or low.  
It can be charged, but it may take a few hours to complete the charging normally.
- Once normal charging starts, the charging lamp lights up green. However, depending on the conditions of use, even when normal charging is taking place, the charging lamp may keep flashing in approx. 4 second intervals until charging is completed.

### Flashing with approx. 0.5 second period (on for approx. 0.25 second, off for approx. 0.25 second):

- The battery is not charged. Remove the battery from the unit, and try charging again.
- Check that the terminals of the unit or battery are not dirty or covered with a foreign object, and connect the battery correctly once again.  
If a foreign object or dirt is present, turn off the unit before removing.

- The battery or environment is at an extremely high or low temperature. Wait until the temperature has returned to an appropriate level and try charging again. If you are still unable to charge, there may be a fault in the main unit, battery or AC adaptor.

**Off:**

- Charging has finished.
- If the status indicator stays off despite the charging being unfinished, there may be a fault in the unit, battery or AC adaptor.
- If the operating time is very short even after the battery has been recharged, the battery has worn out. Please purchase a new battery.

## LCD monitor and viewfinder

- The LCD monitor and viewfinder\* are managed with high precision so that at least 99.99 % of the dots are effective pixels and 0.01 % or less are invalid pixels and always lit. This is not a malfunction and it has no effect whatsoever on the recorded images.
- \* **X2100** / **X1600** is equipped with a viewfinder. **X1200** is not equipped with a viewfinder.

## Memory cards

The SD cards can be used with the camera.

- Do not perform the following operations when accessing the memory card (the card 1 access lamp/card 2 access lamp is flashing in orange).
  - Removing the memory card
  - Disconnecting battery or the AC adaptor without turning off the main unit
  - Apply vibration or impact
- Keep the memory card out of reach of children to prevent swallowing.





## ❖ Speed Class during shooting

The memory card to use differs depending on the file format and the recording format.

Use memory cards compatible with the Speed Class or UHS Speed Class.

The recording may stop suddenly when a memory card not compatible with the required Speed Class is used.

Speed Class and UHS Speed Class are the speed specification regarding continuous writing. Check the display on the label and other information on the memory card.

File format	Supported memory cards	Recording bit rate or recording function	Speed Classes
MOV*/MP4	SDXC memory card	200 Mbps, 150 Mbps, 100 Mbps, Super slow recording	UHS Speed Class 3 
		72 Mbps or less	Speed Class 10, UHS Speed Class 1 or better  CLASS 
AVCHD	SDHC/SDXC memory card	All	Speed Class 4 or better  CLASS 

\* Available for setting when using  / .

## Using commercially-available products

- Use a Premium High Speed HDMI cable (Type A-Type A plug).
- Use a USB cable conforming to the USB specification that is 1.5 m or less in length.
- (For the **X2100** )  
It is recommended to use a double shielded BNC cable equivalent to 5C-FB.
- You can remotely control some of the camera's functions by connecting a remote control unit (commercially-available) to the <REMOTE> terminal.

## About using a headphone

- Excessive sound pressure from earphones and headphones can cause hearing loss.
- Listening at full volume for long periods may damage the user's ears.

## Exemption of liability

Panasonic is not liable in any way regarding following.

- 1 Incidental, special, or consequential damages caused directly or indirectly by the unit
- 2 Damages, breakage of the unit, etc., caused by misuse or carelessness of the customer
- 3 When disassembly, repair, or modification of the unit is performed by the customer
- 4 Inconveniences, damnification, or damages by not being able to record and/or display the video due to any reasons including failure or malfunction of the unit and recording media
- 5 Inconveniences, damnification, or damages resulting from malfunction of the system combining with any third party equipment
- 6 A liability claim or any claim for a privacy violation by an individual or a group that was the subject of the video that the customer has shot (including recording) that became public by any reason (including using with the network user authentication turned OFF)
- 7 The registered information is lost due to any reason (including initializing this unit because the authentication information such as user name or password is forgotten)

## ❖ Be careful with regard to copyrights

Under copyright law, you may not use the images and audio you have recorded for other than personal enjoyment without the permission of the copyright holder.

## How to read this document

### Models described in these operating instructions

- The external design and specifications of this product, as described in this document, may differ from the actual product.
- Illustrations used in this document may differ from the actual product and the actual images displayed on the product.
- Images used in this document are sample pictures used to explain the functions and effects.
- Unless specifically stated otherwise, screen depictions and illustrations of the unit are of HC-X2100.
- Not all models may be available depending on the region of purchase.
- Model numbers are abbreviated as follows in these operating instructions:

Model number	Abbreviation used in these operating instructions	
HC-X2100	X2100	[X2100]
HC-X1600	X1600	[X1600]
HC-X1200	X1200	[X1200]

### Conventions used in this manual

- Words and phrases in [ ] brackets indicate content displayed in the LCD monitor.
- Words and phrases in < > brackets indicate design text used on this unit, such as button names.

# Contents

---

Information for Your Safety .....	2
Cautions for use .....	6
Preparations before recording .....	13
Main specifications .....	25
Trademark .....	28

---

## For United Kingdom and Ireland customers

### Sales and Support Information

#### Customer Communications Centre

- For customers within the UK: 0344 844 3899
- For customers within Ireland: 01 289 8333
- Monday–Friday 9:00 am – 5:00 pm (Excluding public holidays).
- For further support on your product, please visit our website:  
[www.panasonic.co.uk](http://www.panasonic.co.uk)

#### Direct Sales at Panasonic UK

- Order accessory and consumable items for your product with ease and confidence by phoning our Customer Communications Centre  
Monday–Friday 9:00 am – 5:00 pm (Excluding public holidays).
- Or go on line through our Internet Accessory ordering application at  
[www.pas-europe.com](http://www.pas-europe.com).
- Most major credit and debit cards accepted.
- All enquiries transactions and distribution facilities are provided directly by Panasonic UK.
- It couldn't be simpler!
- Also available through our Internet is direct shopping for a wide range of finished products. Take a browse on our website for further details.

# Preparations before recording

## Accessories

Check the accessories before using this unit.

Product numbers correct as of January 2025. These may be subject to change.

### Battery pack

AG-VBR59

(This is referred to as battery pack or battery in this document.)

### Lens hood<sup>\*1</sup>

DVYE1263Z

#### ■ For the X2100 / X1600

The following accessories are also supplied.

### Eye cup

DVHG1323Z

#### ■ For the X2100

The following accessories are also supplied.

### Handle unit

VW-HU1

1AC1R25SXZ

### Microphone holder



### Microphone holder mounting screws<sup>\*2</sup>



1PP1R25SXZ

- Length 12 mm (x2)

\*1 Pre-attached to the main unit.

\*2 The microphone holder mounting screws are supplied with the microphone holder.

• Appropriately discard the packing materials after taking the product out.

• Keep the light cover out of reach of children to prevent swallowing.<sup>\*3</sup>

• Keep the microphone holder mounting screws out of reach of children to prevent swallowing.<sup>\*4</sup>

\*3 The light cover is fitted to the handle unit.

\*4 The microphone holder mounting screws are supplied with the handle unit.

## Description of parts

### ❖ Main unit

- The illustrations in this document show the handle unit ( **X2100** supplied, **X1600** optional) removed.
- **X1200** does not support the handle unit.

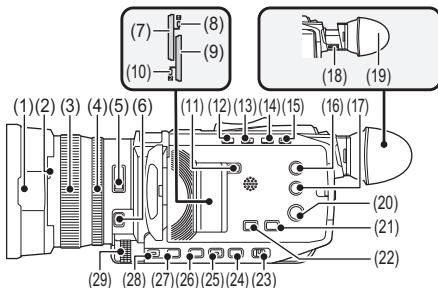

- |   |   |
|---|---|
| (1) Lens hood                               | (For the <b>X1200</b> )                     |
| (2) Lens cover switching lever              | <LCD B. LIGHT>/<USER4> button               |
| (3) Focus ring                              | (16) <THUMBNAIL> button                     |
| (4) Rear ring                               | (17) <DISP/MODE CHK> button                 |
| (5) <ND FILTER> switch                      | (18) (For the <b>X2100</b> / <b>X1600</b> ) |
| (6) <FOCUS A/M/∞> button                    | Diopter adjustment dial                     |
| (7) Card slot 1                             | (19) (For the <b>X2100</b> / <b>X1600</b> ) |
| (8) Card 1 access lamp                      | Eye cup (→ 17)                              |
| (9) Card slot 2                             | (20) Power button (→ 23)                    |
| (10) Card 2 access lamp                     | (21) <WHITE BAL> button                     |
| (11) <SLOT SEL> button                      | (22) <AE LEVEL>/<USER6> button              |
| (12) <USER1> button                         | (23) <AUTO/MANU> switch                     |
| (13) <USER2> button                         | (24) <SHUTTER> button                       |
| (14) (For the <b>X2100</b> / <b>X1600</b> ) | (25) <GAIN> button                          |
| <O.I.S.>/<USER3> button                     | (26) <IRIS> button                          |
| (For the <b>X1200</b> )                     | (27) <MENU> button                          |
| <FACE DET.>/<USER3> button                  | (28) <EXIT> button                          |
| (15) (For the <b>X2100</b> / <b>X1600</b> ) | (29) Multidial                              |
| <VF>/<USER4> button                         |   |

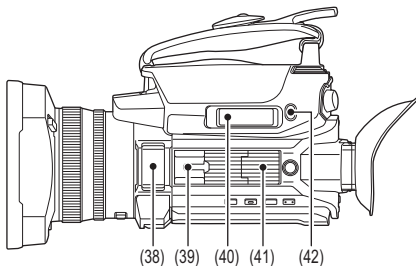
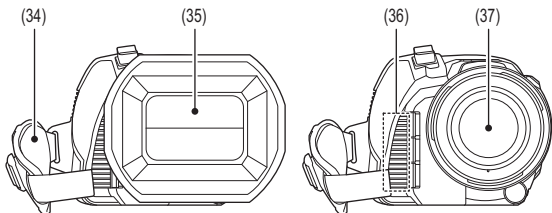
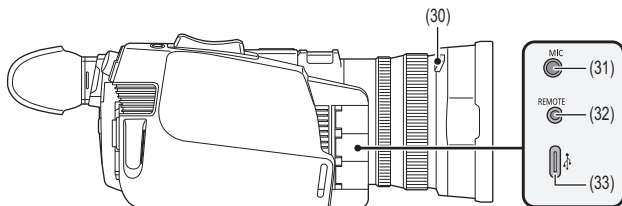

(30) Lens hood release button

(31) <MIC> terminal

(32) <REMOTE> terminal

(33) USB terminal

(34) Grip belt (→16)

(35) Lens cover

(36) Fan outlet

(37) Lens

(38) Built-in microphone

(39) Accessory shoe (on the main unit)

(40) Zoom lever (on the grip)

(41) (For the **X2100** / **X1600**)

Handle unit mounting section (→17)

(42) <USER5> button

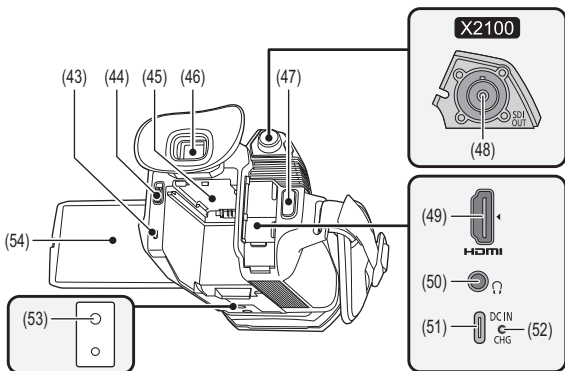

(43) Status indicator (→ 23)

(44) Battery release lever (→ 20)

(45) Battery mounting section (→ 20)

(46) (For the **X2100** / **X1600**)

Viewfinder

(47) REC button (on the grip)

(48) (For the **X2100**)

<SDI OUT> terminal

(49) <HDMI> terminal

(50) Headphones terminal

(51) DC IN terminal (→ 21)

(52) Charging lamp (→ 21)

(53) Tripod mounting holes

(54) LCD monitor

## Attaching accessories

### Adjusting the grip belt

- Adjust the grip belt so that it fits the size of your hand.
- If the buckle is difficult to tighten, move the pad backward and tighten the buckle again.

(A) Buckle

(B) Pad

**1** Open the buckle section.

**2** Pull the end of the belt.

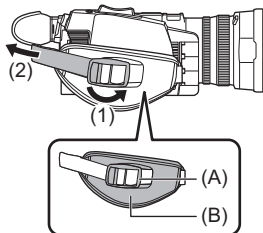

## Attaching the eye cup ([X2100]/[X1600])

- 1 Attach the eye cup by aligning the groove on the mounting part of the eye cup with the inner ridge of the eye cup.

The illustration at right shows an example of fitting for use with the right eye. If you rotate the eye cup to the left by 180° before attaching it, you can use it with your left eye.

- (A) Groove  
(B) Ridge

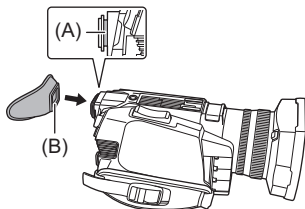

## Attaching the handle unit ([X2100] supplied, [X1600] optional)

- **X1200** does not support the handle unit.
- Press the power button to turn off the unit. (→23)

- 1 Open the microphone holder.

Open buckle (1), and detach fitting (2) from hook (3).

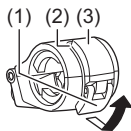

## 2 Attach the microphone holder to the microphone holder mounting section on the handle unit.

- Attach using a commercially-available screwdriver.
- There will be some rubbing noises with the rubber when screwing in the microphone holder mounting screws, but please ensure they are done up tightly.

(A) Microphone holder

(B) Microphone holder mounting screws

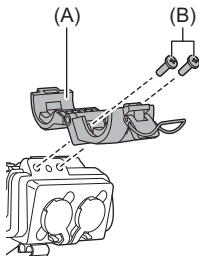

## 3 Push the handle unit into the handle unit mounting section on the camera.

Match the positions of mounting mark (C) on the handle unit and mounting mark (D) on the camera when pushing in.

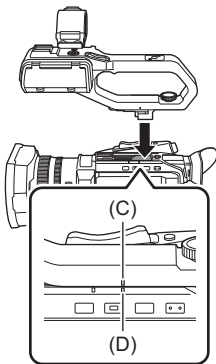

- 4 Slide the handle unit in the direction indicated by the arrow.**

Slide up to mounting mark (E).

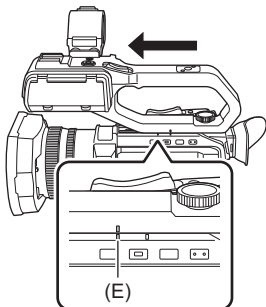

- 5 While pressing the handle unit mounting screw down, turn it in the direction indicated by arrow (2) until it stops.**

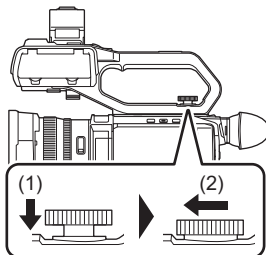

### ❖ How to remove

Remove by doing the steps for attaching in reverse.

## Power supply

A battery or an AC adaptor (optional/commercially available) can be used as the power supply for the unit.

- The unit is compatible to following batteries. (As of January 2025)
  - AG-VBR59 (supplied/optional, supports quick charging)
- AG-VBR59 supports quick charging. Use a battery charger (AG-BRD50: optional) to perform quick charging.

## Attaching and removing the battery

- Press the power button to turn off the unit. (→23)

- 1 Push the battery against the battery mounting section (A) on the main unit and slide forward to attach.

Press in the battery until it clicks and gets locked.

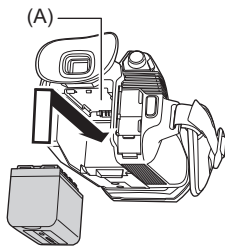

### ❖ Removing the battery

Be sure to hold down the power button until the status indicator (B) goes off. Then remove the battery while supporting the unit to prevent it from dropping.

- Move the battery release lever in the direction indicated by the arrow (1) and remove the battery when unlocked.

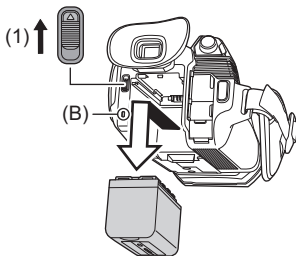

## Charging the battery

Charge using an AC adaptor (optional/commercially available) and a USB cable (commercially available).

The battery is not charged at the time of purchase. Use only after charging sufficiently. It is recommended that you have one extra battery.

- It is recommended to perform charging of the battery in a location with ambient temperature of 10 °C to 30 °C (same for the battery temperature).
- The battery is not charged when the power is on.

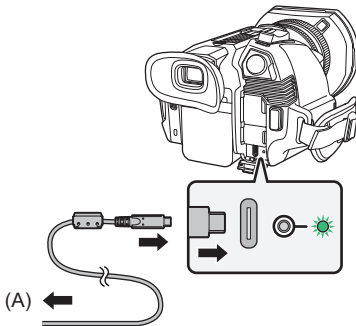

(A) To the AC adaptor

### 1 Connect the USB cable to the AC adaptor and to the DC IN terminal of this unit.

- Insert the USB cable as far as they will go.

### 2 Insert the AC adaptor into an AC outlet.

- As the charging lamp lights up green, charging starts. It will turn off when the charging is completed.
- If the charging lamp flashes, refer to page 7.

## ❖ Connecting to the AC outlet

It is possible to use this unit with power supplied from the AC outlet by turning on the unit with the AC adaptor connected.

Even when you use the AC adaptor for recording images, keep the battery connected.

This allows you to continue the recording even if a power failure occurs or the AC adaptor is unplugged from the AC outlet by accident.

- We recommend using an optional Panasonic AC adaptor (DMW-AC11) to supply power and charge.
- You can also charge with a battery charger (AG-BRD50: optional).
- A commercially available AC adaptor and USB cable can be used to supply power and charge this unit.
  - \* Recommended specifications for the commercially available AC adaptor
    - Supports PD (Power Delivery)
    - Supports 9 V/3 A (27 W) DC output
    - USB Type-C terminal
  - \* For supplying power and charging, use a USB cable with an output rating of 27 W or greater.
- You can also use an AC adaptor with 5 V/500 mA or better for charging. However, charging time may be longer than with the recommended AC adaptor.
- Operation is not guaranteed with all commercially available devices.
- We recommend using Panasonic batteries (→ 20).
- If you use other batteries, we cannot guarantee the quality of this product.
- Do not heat or expose to flame.
- Do not leave the battery(ies) in a car exposed to direct sunlight for a long period of time with doors and windows closed.
- Do not expose to low air pressure at high altitudes.
- Do not expose to extremely low air pressure, as this may result in explosions or leakage of flammable liquids and gases.

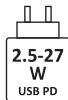

### USB PD fast charging

The power delivered by the charger must be between min. 2.5 Watts required by this product, and max. 27 Watts in order to achieve the maximum charging speed.

## Turning the unit on/off

### 1 Open the LCD monitor and press the power button (A) to turn on the unit.

- The status indicator (B) lights on.

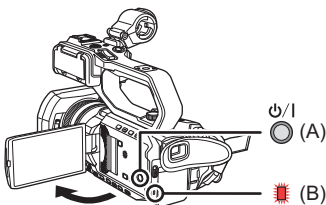

### ❖ To turn off the unit

Hold down the power button until the status indicator goes off.

## When turning on the power for the first time

The time zone, date, and time are not set when the unit is shipped.

[TIME ZONE] is displayed in the LCD monitor when the power is turned on for the first time.

Follow the guidance and make the settings in the order of [TIME ZONE] and then [CLOCK SETTING].

### ❖ [TIME ZONE]

Set the time difference from the Greenwich Mean Time.

(A) [TIME ZONE]

1 **Set the time difference.**

2 **Select [SET].**

Once the setting for [TIME ZONE] is completed, the [CLOCK SETTING] screen is displayed.

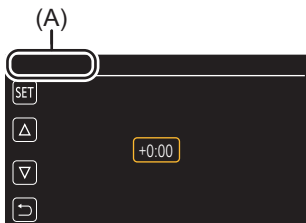

- The setting for the date/time of the main unit changes together with the time zone settings.

### ❖ [CLOCK SETTING]

Set the year, month, date, and time.

(A) [CLOCK SETTING]

(B) 0 : 0 1. JAN. 2025

1 **Set the year, month, date, and time.**

The year can be set between 2024 and 2037.

2 **Select [SET].**

Once the setting is complete, the camera image screen is displayed.

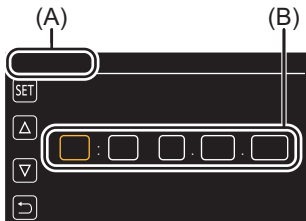

# Main specifications

<b>Power</b>	7.28 V $\equiv$ (when battery is used) 9.0 V $\equiv$ (when the AC adaptor is used)
<b>Power consumption</b>	<b>X2100</b> Recording; 19.8 W, Charging; 15.5 W <b>X1600</b> / <b>X1200</b> Recording; 12.3 W, Charging; 15.5 W
<b>Ambient operating temperature</b>	0 °C to 40 °C
<b>Ambient operating humidity</b>	10 %RH to 80 %RH (no condensation)
<b>Mass</b>	<b>X2100</b> Approx. 0.85 kg <sup>*1</sup> /Approx. 1.5 kg <sup>*2</sup> <b>X1600</b> Approx. 0.85 kg <sup>*1</sup> /Approx. 1.2 kg <sup>*2</sup> <b>X1200</b> Approx. 0.80 kg <sup>*1</sup> /Approx. 1.1 kg <sup>*2</sup>  *1 Main unit only, excluding handle unit ( <b>X2100</b> only), lens hood, battery, and eye cup ( <b>X2100</b> / <b>X1600</b> only) *2 Including handle unit ( <b>X2100</b> only), lens hood, battery and eye cup ( <b>X2100</b> / <b>X1600</b> only)
<b>External dimensions (W×H×D)</b>	<b>X2100</b> 129 mm×159 mm×267 mm <b>X1600</b> 129 mm×93 mm×267 mm <b>X1200</b> 129 mm×93 mm×209 mm (including handle unit ( <b>X2100</b> only), lens hood, and eye cup ( <b>X2100</b> / <b>X1600</b> only), excluding microphone holder ( <b>X2100</b> only) and protrusions)
<b>Pickup device</b>	1/2.5 type (1/2.5 ") MOS solid-state image sensing device for colors Total pixels: approx. 8,570,000 pixels
<b>Number of effective pixels</b>	Approx. 8,290,000 pixels
<b>Lens</b>	Optical image stabilizer lens, motorized 24× zoom F value: F1.8 to F4.0 Focal length: f=4.12 mm to 98.9 mm 35 mm conversion: f=25.0 mm to 600.0 mm
<b>Filter diameter</b>	62 mm

<b>USB terminal</b>	USB Type-C®×1, (High-Speed USB) USB2.0 <b>X2100</b> : Host/device combined (switched with menu) Host: Supports bus power (5 V, 0.5 A), USB tethering functionality, USB ethernet adaptor functionality Device: USB mass storage functionality (read only) <b>X1600</b> / <b>X1200</b> : USB mass storage functionality (read only)
<b>DC IN terminal</b>	9 V/3 A, USB Type-C®×1, compatible with USB-PD
<b>LCD monitor</b>	8.8 cm (3.5 ") LCD monitor: approx. 2,760,000 dots Capacitive touch screen
<b>X2100</b> / <b>X1600</b> <b>Viewfinder</b>	1.0 cm (0.39 ") OLED (organic EL display): approx. 2,360,000 dots Video display area: approx. 1,770,000 dots

### Wi-Fi ([X2100]/[X1600])

<b>Compliance standard</b>	IEEE802.11a/b/g/n/ac (standard wireless LAN protocol)
<b>Frequency range used (central frequency)</b>	2412 MHz to 2462 MHz (1 to 11ch) 5180 MHz to 5320 MHz (36/40/44/48/52/56/60/64ch) 5500 MHz to 5700 MHz (100/104/108/112/116/120/124/128/132/136/140ch) 5745 MHz to 5825 MHz (149/153/157/161/165ch)
<b>Encryption method</b>	Wi-Fi compliant WPA2™ / WPA3™
<b>Access method</b>	Infrastructure mode

**Handle unit ([X2100] supplied)****Input voltage**23.6 V/5 V/3.15 V  $\equiv$ **Power consumption**

Maximum approx. 3.1 W (when connected to the camera)

<b>Mass</b>	Approx. 305 g (main part of the handle unit only, excluding microphone holder and microphone holder mounting screws)
<b>External dimensions (W×H×D)</b>	Approx. 71 mm× 89 mm× 207 mm (including protrusions, excluding microphone holder)

**Battery pack (AG-VBR59)**

<b>Voltage/capacity</b>	7.28 V $\equiv$ 5900 mAh 43 Wh
-------------------------	--------------------------------

The symbols on this product (including the accessories) represent the following:

$\equiv$ DC	ON	⏻ Standby
-------------	----	-----------

# Trademark

---

- SDXC logo is a trademark of SD-3C, LLC.
- “AVCHD”, “AVCHD Progressive” and the “AVCHD Progressive” logo are trademarks of Panasonic Holdings Corporation and Sony Corporation.
- Manufactured under license from Dolby Laboratories. Dolby, Dolby Audio, and the double-D symbol are trademarks of Dolby Laboratories Licensing Corporation.
- The terms HDMI, HDMI High-Definition Multimedia Interface, HDMI Trade dress and the HDMI Logos are trademarks or registered trademarks of HDMI Licensing Administrator, Inc.
- USB Type-C® and USB-C® are registered trademarks of USB Implementers Forum.
- X2100 and X1600 correspond to Wi-Fi functions.

Covered by patents at [patentlist.accessadvance.com](http://patentlist.accessadvance.com)
- The Wi-Fi CERTIFIED™ Logo is a registered trademark of Wi-Fi Alliance®.
- “Wi-Fi®” is a registered trademark of Wi-Fi Alliance®.
- “WPA2™” and “WPA3™” are trademarks of Wi-Fi Alliance®.
- QR Code is a registered trademark of DENSO WAVE INCORPORATED.
- All other names, company names, product names, etc., contained in this instruction manual are trademarks or registered trademarks of their respective owners.

---

At least three (3) years from delivery of this product, Panasonic will give to any third party who contacts us at the contact information provided below, for a charge no more than our cost of physically performing source code distribution, a complete machine-readable copy of the corresponding source code covered under GPL V2.0 or LGPL V2.1, as well as the respective copyright notice thereof.

Contact Information: [oss-cd-request@gg.jp.panasonic.com](mailto:oss-cd-request@gg.jp.panasonic.com)

The source code and the copyright notice are also available for free in our website below.

<https://docs.connect.panasonic.com/oss/>

---

This product is licensed under the AVC Patent Portfolio License for the personal use of a consumer or other uses in which it does not receive remuneration to (i) encode video in compliance with the AVC Standard ("AVC Video") and/or (ii) decode AVC Video that was encoded by a consumer engaged in a personal activity and/or was obtained from a video provider licensed to provide AVC Video. No license is granted or shall be implied for any other use. Additional information may be obtained from MPEG LA, L.L.C.

See <http://www.mpegla.com>

- Separate license contract with MPEG-LA is required to record in a memory card with this product and to distribute that card to end users for a profit. The end user mentioned here indicates a person or organization that handles contents for a personal use.

## 2023 No. CONSUMER PROTECTION

### The Product Security and Telecommunications Infrastructure (Security Requirements for Relevant Connectable Products) Regulations 2023

#### Statement of compliance

We hereby deliver our Statement of Compliance for product (type, batch);

#### Digital Video Camera

Refer to the website below for compliant models and their support periods.

[https://panasonic.jp/support/global/cs/info/im\\_sec\\_info.html](https://panasonic.jp/support/global/cs/info/im_sec_info.html)

**Name / address of each manufacturer of the product and authorised representative;**

Manufacturer name: Panasonic Entertainment & Communication Co., Ltd.

Address: 1-10-12 Yagumo-higashi-machi, Moriguchi City, Osaka  
570-0021, Japan

Representative: TOSHIYUKI TSUMURA

**Declaration of compliance that, in the opinion of the manufacturer, we have complied with the deemed compliance conditions in Schedule 2;**

- 1. No universal default passwords: Complies with ETSI EN 303 645 provisions 5.1-1, 5.1-2**
- 2. Product Security vulnerability report: Complies with ETSI EN 303 645 provisions 5.2-1**

Panasonic Product Security Incident Response Team link:

<https://holdings.panasonic/global/corporate/product-security.html>

- 3. Security update periods: Complies with 5.3-13 of ETSI EN 303 645**

Panasonic product security update link:

[https://panasonic.jp/support/global/cs/info/im\\_sec\\_info.html](https://panasonic.jp/support/global/cs/info/im_sec_info.html)

**Statement of Compliance signatory;**

**Company name: Panasonic Entertainment & Communication Co., Ltd.**

Signature by:

*Toshiyuki Tsumura*

Name: TOSHIYUKI TSUMURA

Title: Director, Imaging Solution Business Division

Place: 1-10-12 Yagumo-higashi-machi, Moriguchi City, Osaka, Japan

Date: 29/5/2024